

NEMO QUALITY

There is a reason why our logo resembles a medieval shield. If you've ever seen an authentic medieval shield or piece of armor, the detail and quality of craftsmanship are astonishing. Hours were spent shaping and perfecting every component knowing the gravity of purpose and the need for reliable performance. At NEMO, we take the same approach to quality. We know from our own experience how vital a tent can be for comfort and survival. Your tent is your home in the wilderness and your armor against the elements. We obsess over every design decision to ensure you get the greatest comfort and protection possible. Our process begins with pencil and paper and evolves methodically through computer modeling, prototyping, testing and development. We use all the latest tools, software, manufacturing methods and materials. If we aren't happy with what's available we make our own. We strive to design and build the best tents on the planet. We stand behind our shield, the symbol of NEMO quality.

To learn more, please visit our website at www.nemoequipment.com.

MORPHO AR™

Exploring the Future.

There is no substitute for confidence in your gear, especially in your tent. We've carefully fine-tuned Morpho AR™ to be the perfect companion for your extended adventures in the wilderness. There are no metal poles with Morpho AR™. Instead, this tent features 3.5" diameter NEMO airbeams which are stronger than conventional tent poles, much easier to set up, and pack considerably smaller. The interior length of the tent is 9' so you have plenty of room to store your gear inside, within easy reach. Most of Morpho AR™ is a single wall tent, but the front third of the tent is double walled. We call this design ExoFly™. It allows you to retract a portion of the inner tent when a vestibule is needed, but otherwise you get an exceptional 40 sq ft of usable interior space at only 4.8 lbs.

Capacity:	2
Minimum Weight:	4.8 lbs (2.17 kg)
Packed Weight:	5.7 lbs (2.58 kg)
Packed Dimensions:	14" x 7" dia (35.5 x 17.7 cm)
Frame:	3.5" Diameter Airbeams
Shell Fabric:	OSMO™ Waterproof Breathable 30D Sil/PU Nylon Ripstop
Fly Fabric:	N/A
Floor Fabric:	30D PU Nylon Ripstop (5000 mm)
Floor Dimensions:	112" x 64" (285 x 163 cm)
Interior Height:	42" (107 cm)
Floor Area:	40 sq ft (3.71 sq m)
Vestibule Area:	14 sq ft (1.31 sq m)



MORPHO AR™

AirSupported Technology®

Product Features

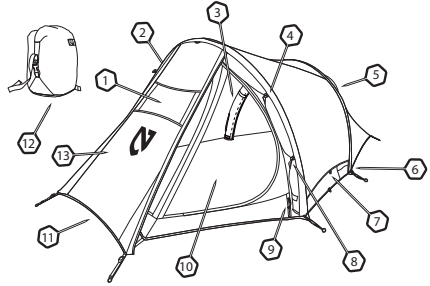

1. UVX Window
2. LightPocket™
3. Removable Airbeams
4. Door Tie-Backs
5. Rear Scoop Style Vent
6. Pump Access Zipper
7. Internally Deployable Vent
8. Multiple Guy-Out Points
9. Pump Access Zipper
10. Mesh Canopy With Two Entries
11. ExoFly™ Vestibule
12. Dry Bag Style Stuff Sack
13. Second Door

Nemoid™ Pump and Airbeam

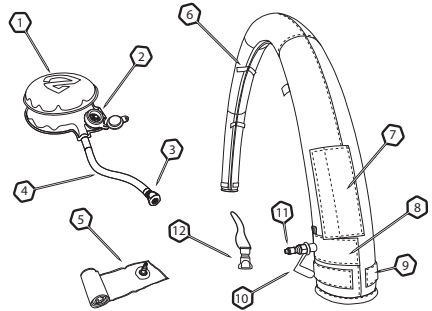

1. Nemoid™ Foot Pump Body
2. Dump-Check Valve™
3. Quick-Disconnect Fitting
4. Neoprene Hose
5. Spare Bladder (Sold Separately)
6. Velcro® Attachment Straps
7. Bladder Access Pocket
8. Hypalon® Reinforcement
9. Velcro® for Airbeam Ends
10. Protective Cap for Valve
11. Inflate/Deflate Valve
12. Deflator Cap

NEMO Innovation

1. **Ventilation:** all NEMO tents take comfort very seriously. We've developed our own lightweight waterproof breathable fabric, OSMO™, to provide the best combination of weight, durability and performance. Morpho AR™ also has two side vents and a rear scoop vent. The front ExoFly™ also increases ventilation.

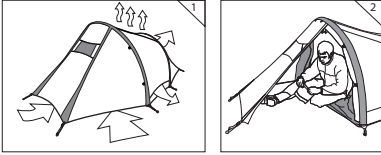

2. **ExoFly™ Retractable Vestibule:** Morpho AR™ features a unique morphing vestibule. The tent is designed to store gear inside where it can stay dry and close at hand, but if you need a temporary vestibule simply unclip and retract the inner tent from the fly.

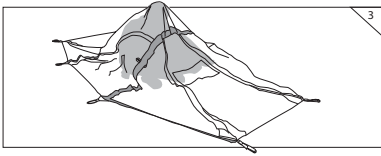

3. **Setup From Inside:** NEMO AirSupported Technology® allows you to set up the tent from the inside during bad weather. After staking out your Morpho AR™, get inside and take your time pumping up the airbeams while staying dry.

4. **LightPocket™:** most headlamps have a focused beam and hanging your lamp inside your tent can be frustrating. To make things easier, Morpho AR™ includes a special pocket for your headlamp with a light diffusing fabric. Place your lamp in the pocket with the light facing towards the inside of the tent, and the LightPocket™ will help cast an even glow throughout the tent interior.



Preparing Your Tent

1. Lay out the contents of Morpho AR™ and make sure you received your tent and the following items: stuff sack, Nemo™ Foot Pump, eight stakes, guy lines, and repair kit.

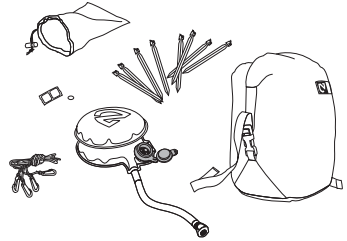

2. **NOTE: AIRBEAMS DO NOT NEED TO BE REINSTALLED EVERY TIME THE TENT IS SET UP.** If your airbeams are already attached, please skip to **Tent Setup**. If not, stake the corners of the tent, and connect the long airbeam to the tent using the Velcro® straps. The long airbeam should be attached along the black strip closest to the front door.

NOTE: Make sure the inflate valve is on the side near the pump access zipper.

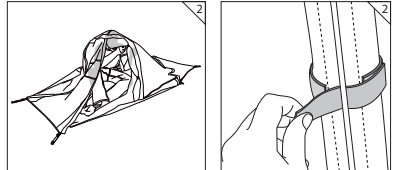

3. Inflate the long airbeam as described in the **Tent Setup** section. Make sure the Velcro® straps are not too loose or too tight. They should hold the airbeam to the tent firmly in place without puckering the airbeam fabric.

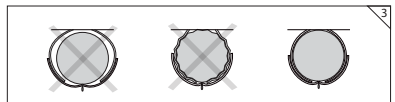

4. With the front airbeam installed and inflated, repeat the process with the short airbeam.

Tent Setup

1. When choosing a location to pitch your tent, select a flat area free of fragile undergrowth and sharp objects. Anchor the corners of the tent to the ground with the included stakes. If you are forced to set up your tent on an incline, make sure your head is positioned uphill. If the ground is too hard to place stakes, tie the corners of your tent to heavy objects like rocks.



2. Inside the airbeam access zippers, locate an airbeam valve and disconnect the deflator cap. Connect your Nemoid™ Foot Pump to the inflate/deflate valve. When properly connected, the quick-disconnect fittings will make an audible click. When inflating from outside the tent, pass the pump hose through the pump access zipper.

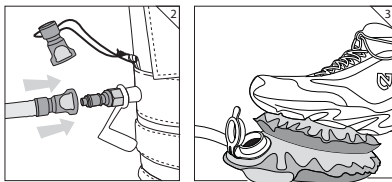

3. Step on the pump body repeatedly until it becomes impossible to fully compress the pump with your own body weight. Disconnect the pump and attach the red protective cap. Repeat the process with the second airbeam.

4. For maximum stability, stake out all of the corner anchors. Adjust the webbing straps on each anchor to create an even tension throughout the entire tent shell.

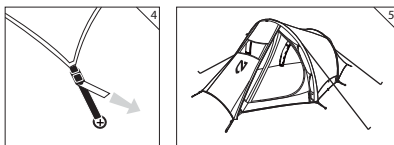

5. In extreme weather, attach the supplied guy lines to the guy-out loops and stake in place. In high winds, it is best to face the front or rear of your tent into the wind.

6. Place your headlamp in the LightPocket™ to create an even glow inside your tent.



Accessories

Spare Bladder

Weighing only 2.7 oz, a spare bladder is an excellent addition to your repair kit for backcountry travel. In the rare event that you need to change your airbeam bladder, it will allow you to quickly swap the spare without having to check for leaks or repair holes.

Morpho™ Footprint

To install the Morpho AR™ Footprint, slip the split rings over each of the eight corresponding corner anchors. The NEMO label on the Footprint will be at the front of the tent.



Morpho™ Padlock™

To install the Morpho AR™ Padlock™, take the end of the long strap and sandwich it between the Velcro® loops on the bottom of the long airbeam and the Velcro® hooks near the tent foot. Repeat with the short strap and the short airbeam. Insert your pads between the padlock webbing straps and position them as you wish. You can slide the small plastic ladder lock buckles on the webbing to trap the pads in place.

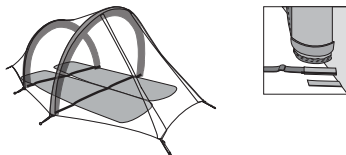

Morpho™ Pawprint™

To install the Morpho AR™ Pawprint™, snap the corners to the snaps inside the Morpho AR™ inner tent. The NEMO label will be at the front of the tent. The Pawprint™ can stay connected to the tent when the tent is packed.



Tips for Extending the Life of Your Tent

- △ Avoid rough ground, especially rocks and pavement.
- △ Make sure the tent is clean and dry before packing.
- △ Store the tent unpacked to allow air circulation.
- △ Occasionally inspect the tent for wear and tear.
- △ Do not store the tent exposed to UV light.
- △ Do not store Nemoid™ Foot Pump compressed.

Repairing Bladders

NEMO AirSupported tents are designed to withstand all the usual rigors of adventure. We worked hard to select materials with the right balance of being lightweight and durable. If you take reasonable care of your tent, you should never have a problem. But, accidents do happen! If you have a puncture, the next few steps will show you how to swap in a new bladder and repair the damaged one to keep as a spare. Please read all the steps first before beginning.

Repairing small holes in a NEMO bladder is simple. Refer to the **Exchanging Bladders** section below to remove the bladder from the airbeam. If necessary, inflate the bladder and hold under water to locate the puncture.

1. Make sure the area around the puncture is dry and clean.
2. Cover the hole with a generous piece of the self-adhesive patch (TEAR-AID™) included in your repair kit. Make sure there is at least 3/8" between the hole and the edge of the patch.

NOTE: If the damage is larger than 1/8" in length or diameter, the repair may not be reliable. Replacement bladders are available from www.nemoequipment.com.

Exchanging Bladders

If you do not have a spare bladder, follow the directions below, but for step 4, tie a piece of cord that is longer than the airbeam to the bladder before you pull it out. Use this cord to pull the bladder back into the airbeam once it has been repaired.

1. Connect the deflator to the airbeam valve to completely deflate the damaged bladder.
2. Open the bladder access pockets of the deflated airbeam. If the puncture is easily accessible, read the **Repairing Bladders** section above for repair instructions.

Tent Take Down

1. To take down Morpho AR™, first remove all gear and as much moisture as possible. Water will add weight to your pack and can cause mildew.

2. Begin by placing the deflator caps on the inflate/deflate valves. When properly connected, there will be an audible click. The airbeams will immediately begin to deflate.

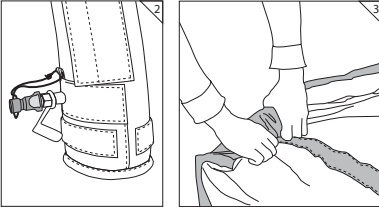

3. Roll the tent along the airbeams towards their valves to force out all the air. Try to clean as much dirt and debris from your tent as possible before packing. This will help preserve the breathability of the tent fabrics and reduce overall wear and tear.

4. Stuff the tent entirely into the stuff sack. By starting with the back end of Morpho AR™ you will avoid trapping air in your stuff sack.

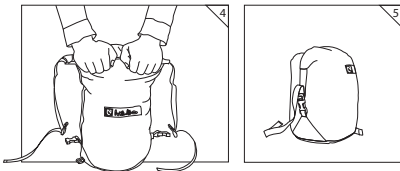

5. Fold the top edge of the stuff sack down several times to make an air-tight seal. Allow excess air to escape while compressing. Secure the stuff sack with the compression straps on both sides.

Storage

Remember to dry your tent out completely before storing as moisture can lead to mildew. Also try to remove as much dirt and debris from your tent as possible. Avoid storing your tent compressed or exposed to UV light for long periods.



3. To swap in a new bladder, push the valve back through its Hypalon® hole. A small amount of force may be needed. Be careful not to tear the airbeam.

4. Tie the valve end of the damaged bladder to the non-valve end of the new bladder. Gently pull on the end of the damaged bladder to drag the new bladder into the airbeam. **NOTE: Be careful not to twist the new bladder while pulling into the airbeam.**

*To prevent twisting, it helps to carefully lay out the new bladder flat on the ground with the valve oriented the right direction. **NOTE: Make sure to use a long bladder when fixing the long airbeam.**

5. Once the new bladder has been pulled into position in the airbeam, untie the damaged bladder. Be certain there is extra bladder material at both ends of the airbeams. Gently press the extra material into the ends of the airbeam without folding. **NOTE: If the bladder does not reach the end of the airbeam, it is likely to burst during inflation.**

6. Push the bladder valve back through the Hypalon® hole in the airbeam. Carefully close both sets of Velcro® for each bladder access pocket. Slowly reinflate the airbeam checking to make sure the bladder reaches the airbeam ends and that there are no kinks. **NOTE: Kinks, or areas where the airbeam is not inflating, are likely due to a twist in the bladder.**

7. Kinks cannot be fixed without removing the bladder. Since kinks require repeating this entire process, it is best to take your time and be sure the new bladder slides into the airbeam with the valve oriented in the right direction and without any twists.



NEVER OPEN BLADDER ACCESS POCKETS WHEN AIRBEAM IS INFLATED.

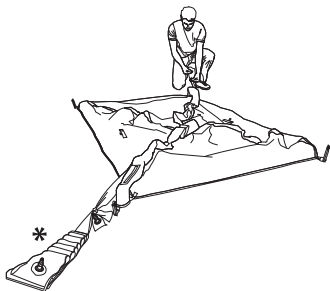

NEMO Repair

If you have any problems with a NEMO product, please contact Rainy Pass Repair, Inc., the industry leader in outdoor product care for repair or replacement. If you have any questions regarding warranty and repair, or if you need to send a product in for service, please call Rainy Pass. It is not necessary to clean the item before sending, but it will be appreciated if you remove any excessive soiling. Rainy Pass will be happy to give you advice about safely cleaning your product. Please provide the following when you send a NEMO product to Rainy Pass:

- △ A note with your name, phone number, address, e-mail and problem description. A repair form can be downloaded at:
www.nemoequipment.com/pdf/NEMO_repairform.pdf
- △ Mark all damaged areas on the product with masking tape.
- △ Pack the product in a sturdy cardboard box with plenty of room. If possible, use the original box to reduce waste.

Ship to:
Rainy Pass Repair, Inc.
4415 Stone Way North
Seattle, WA 98103

To contact Rainy Pass:
Phone: 1.888.747.7867
Email: repair@rainypass.com
www.rainypass.com

NEMO Warranty

NEMO guarantees every product we sell. We put a great effort into choosing the best materials and providing you with the highest level of workmanship. If one of our products does not meet your expectations during its useful life, we promise to repair it, replace it, exchange it, or give you a refund at our discretion. NEMO does not warranty products against normal wear and tear, unauthorized modifications or alterations, improper use, improper maintenance, misuse or neglect or if the product is used for a purpose for which it is not intended. Except as expressly set forth in these terms and conditions, NEMO is not liable for any direct, indirect or consequential damages arising out of or resulting from the use of a NEMO product. The warranties set forth in these terms and conditions are in lieu of all other warranties, express or implied, including without limitation, implied warranties of merchantability or fitness for a particular purpose.



NEMO Green

Our spirit is in adventure. Without the beautiful wild places where adventures are made, our spirit dies. Please join us in protecting the planet and preserving the places where our spirit thrives.

NEMO is a small company but even small companies and individuals can make a difference. Here are some of the green efforts we are currently making:

>We are incorporating sustainability into our product designs with innovations like our 90% recycled/recyclable Nano OZ™ tent, bamboo tent poles and our Ditto™ reusable tote bag made from old tent samples.

>As of 2008, all of our aluminum poles from DAC use a more environmentally friendly anodization process that avoids the use of toxic heavy metals. These poles are also recyclable.

>In 2006 we stopped using PVC in all of our products.

>All of our business partners domestically and overseas run responsible businesses with good working conditions and respect for the environment.

>NEMO employees get one day off every month to pursue a green effort or volunteer with a community organization.

>In 2008, NEMO adopted the northern end of Jenness Beach in North Hampton, NH (a favorite surf spot of many NEMO employees) through the Blue Ocean Society. The adoption enables NEMO to keep the beach clean throughout the year and also track the types of debris to determine whether the trash is ocean-based or land-based.





>NEMO donates to many groups such as the Access Fund and the National Wildlife Federation to help preserve the natural places we cherish. We have also donated tents to help with disaster relief, including donating over 150 winter mountaineering tents to Pakistan in 2005 following the earthquake in Kashmir.

>NEMO provides discounts and donates tents to college outing clubs to encourage students to get outdoors and foster a love for the environment.

>We recycle everything possible in our shop, including re-using packaging materials and we encourage our manufacturing partners to do the same.

>We do as much of our printing as possible on recycled paper with environmentally-friendly inks.



Never place your stove, campfire, or other flame source in or near your tent. Never cook, light, or refuel a stove or any other heat source inside your tent. Death by suffocation and/or serious burns is possible.	Maintain adequate ventilation inside your tent at all times. Death by suffocation is possible.	Anchor your tent properly at all times to reduce the risk of loss or injury to the tent or occupants.	Carefully consider the possibility of falling rocks or tree limbs, lightning strikes, flash floods, avalanches, strong winds, and other hazards when choosing a campsite to reduce the risk of loss or injury.
NO FIRE	VENTILATION	ANCHOR	CAMPSITE
			



WARNING

If you have additional questions, please contact
NEMO Equipment, Inc. directly at 800-997-9301
www.nemoequipment.com

NOTE: All 2009 NEMO tents meet the CPAI-84 standard for flame retardancy.



NEMO MISSION

Our 2008 product line is the result of 6 years of devoted labor and half a million years or so of developing better tools for shelter and survival. NEMO is about what we have just discovered and what we have known for a long time. It's about beautiful design and intelligent engineering. It's about serene cloudless days and bitter cold nights spent battling snow drifts and frostbite. It's about bringing two worlds together: the world of design and technology and the actual world where we test ourselves and our inventions. We are pursuing perfection. It is an epic journey, often elusive, demanding youthful energy, creativity and courage. We have come a long way in our travels and we promise never to yield in our determination. Like our ancestors who explored new places for the first time, we will change the common idea of what is possible.

Please visit us at: www.nemoequipment.com

NEMO EQUIPMENT, INC.

100 FACTORY ST, NASHUA, NH 03060

P: 800-997-9301 F: 603-881-9358

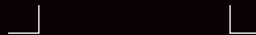

Printed on Recycled Paper



www.nemoequipment.com

©2009 NEMO Equipment, Inc.